

# **OPERATOR'S MANUAL**

Brush Crusher™

# **BC-4400**



**Specialists in Quality and  
Time Saving Farm Equipment**

ONLINE ATTACHMENT CATALOG at: [www.loaders.com](http://www.loaders.com)

**READ AND SAVE THIS BOOK**

A product of Westendorf Manufacturing Co., Inc.

WESTENDORF MFG. CO., INC. • ONAWA, IA 51040 • 712.423.2762 • [www.loaders.com](http://www.loaders.com)

## SECTION 1: INTRODUCTION

### Welcome To The Westendorf Family

Your new Westendorf equipment is the highest quality and time saving machinery available. We urge you to exercise sound judgement in the operation and maintenance of this equipment to assure long, trouble-free use and personal safety. It is important to read this manual thoroughly and understand it completely before assembly or operation of this equipment.

This manual should be considered a permanent part of your equipment and be transferred to the new owner if the equipment is sold. It consists of instructions and guides for operating your new equipment. It should be your first, not last resort when dealing with questions.

Thank you for your purchase of our product. If there is anything further we can do to assure complete satisfaction, contact your Westendorf dealer. If you still need help, please call on us. We will be glad to assist you in any way we can.

Thank You;  
Westendorf Manufacturing

### Terminology



Basic terminology that is used throughout this manual has been identified in the illustration below. Components and instructions in this manual are identified as "left" or "right". This is determined as sitting "in the operators seat facing in the normal direction of travel". See figure.

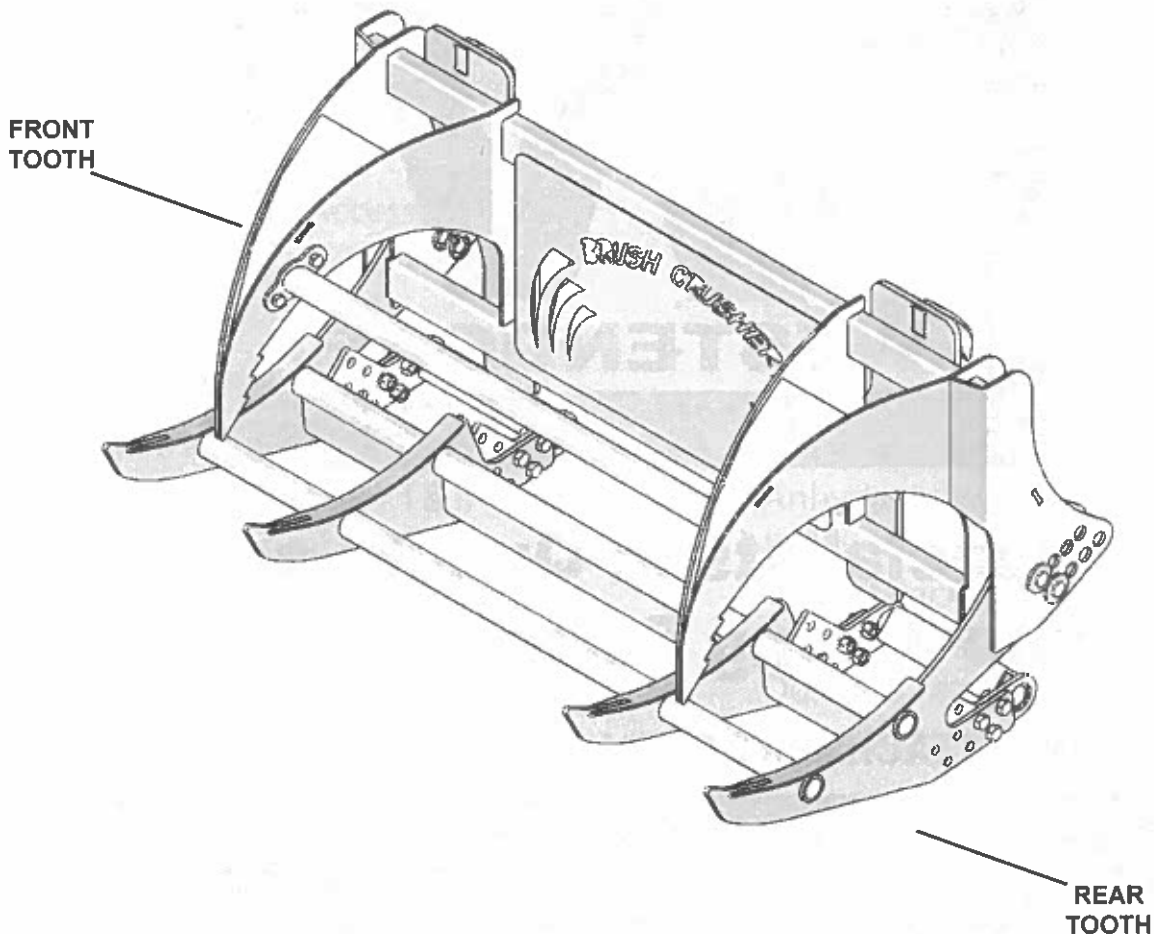

**SECTION 1: CONTENTS**

**Section 1 - Introduction**

Welcome to the Westendorf Family..... 2  
 Terminology ..... 2  
 Table of Contents..... 3  
 Serial Number Location ..... 4  
 Dealer Preparation Checklist..... 4  
 Limited Lifetime Warranty..... 4-5

**Section 2 - Safety**

Recognize Safety Information ..... 6  
 Safety Alert and Signal Words ..... 6  
 Safety Instructions ..... 6  
 Tractor Requirements ..... 6  
 Maintenance and Inspection..... 6  
 Prepare For Emergencies ..... 7  
 Do Not Allow Riders..... 7  
 High Lift Loaders ..... 7  
 Avoid Rollover ..... 7  
 Avoid Power Lines and Underground Utilities ..... 7  
 Lower Operating Speed..... 7  
 Replace Safety Signs ..... 7  
 Prevent Falling Loads..... 8  
 Transport Loads Safely ..... 8  
 Raised Loader ..... 8  
 Avoid High Pressure Fluids ..... 8  
 Hydraulic Control Functions ..... 8  
 Ballast and Tread Settings  
     Determination of Ballast..... 9  
     Minimum Tread Settings ..... 9  
 Round Bale Safety..... 10  
 Balance Uneven Loads Properly ..... 10  
 Handling Your Brush Crusher..... 10  
 Using Your Brush Crusher & Safety Decal Locations 10

**Section 3 - Mounting / Dismounting  
 And Attachments**

Approved Attachments ..... 11

**Section 4 - Operation**

The Mechanical Advantage ..... 12  
 Approaching the Load ..... 12

**Section 5 - Service & Maintenance**

Maintenance Checklist ..... 13  
 Lubrication..... 13  
 Torque Charts ..... 14  
 Parts ..... 15  
 Preparing the Brush Crusher™ for Storage ..... 16  
 Storing the Brush Crusher™ ..... 16 v

**Prop. 65 Warning for California Residents**



**WARNING:** This product may contain chemicals known to the State of California to cause cancer, birth defects, or other reproductive harm.

## SECTION 2: SAFETY

### Recognize Safety Information

This is the safety alert symbol. This symbol identifies important safety messages on your machinery and in this manual. When you see this symbol, be alert to the possibility of personal injury.

Carefully follow the recommended precautions and safe operating practices.



### Safety Alert Symbol And Signal Words

This manual provides instructions for the operation and care of your Westendorf product. The instructions in this manual must be followed to ensure the safety of persons and satisfactory life of the implement. Safety precautions to protect against injury or property damage must be followed at all times.

You must read, understand, and follow the instructions given by the tractor manufacturer, as well as the instructions in this manual.

The safety information in this manual is denoted by the safety alert symbol: 

The level of risk is indicated by the following signal words:

#### **DANGER**

*White letters on RED*

**DANGER** indicates a hazardous situation which, if not avoided, will result in death or serious injury.

#### **WARNING**

*Black letters on ORANGE*

**WARNING** indicates a hazardous situation which, if not avoided, could result in death or serious injury.

#### **CAUTION**

*Black letters on YELLOW*

**CAUTION** indicates a hazardous situation which, if not avoided, may result in minor or moderate injury.

#### **NOTICE**

*White letters on BLUE*

**NOTICE** indicates a property damage message.

### Safety Instructions

Carefully read all safety messages in this manual and on equipment safety signs. Keep safety signs in good condition and replace missing or damaged safety signs. New equipment components and repair parts must include the current safety decal. Safety decals are available at no charge from your Westendorf dealer.

Learn how to properly operate equipment. **NEVER** allow anyone to operate equipment without proper instruction, while fatigued, or under the influence of alcohol, prescription or non-prescription medication.

Keep equipment in proper working condition. Unauthorized modifications to the equipment may impair the function, or more importantly, have an effect on your safety.

Know the regulations and laws that apply to you and your industry. This manual is not to replace any of them. Additional information may be found on the world wide web at: [www.asae.org](http://www.asae.org) or [www.osha.gov](http://www.osha.gov).

If you do not understand any part of this manual, contact your Westendorf dealer.

### Tractor Requirements

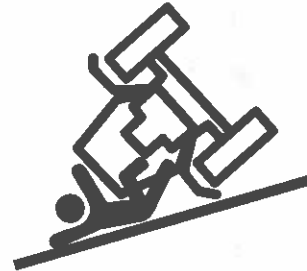

Narrow front end tractors can be unstable when equipped with a front end loader and can rollover. Use extreme caution when operating a narrow front end tractor equipped with a loader.

Operate on level ground only, keep loads low and avoid sharp turns.

Mount loader on a tractor equipped with wide front end and a ROPS or ROPS Cab.

Tractor seat belt must be used for all loader operations.

### Maintenance And Inspection

Inspect for worn or loose parts regularly. Lubricate according to specifications in this manual. Never alter or modify any part of the mounting brackets, loader or attachments. Doing so can result in an unsafe condition and may void the warranty.

## SECTION 2: SAFETY

### Prepare For Emergencies

Be prepared in case of an emergency.  
 Keep a fire extinguisher and first aid kit handy.  
 Keep emergency phone numbers close to your phone.  
 Know your address so emergency services can locate you if an emergency arises.

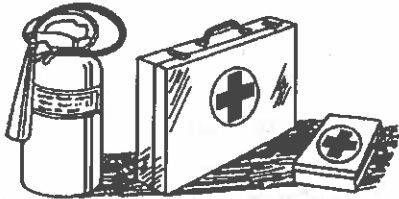

### Do Not Allow Riders

**NEVER** lift or carry anyone with the loader, bucket or attachments.  
**NEVER** use the loader or attachment as a work platform.  
**NEVER** allow passengers on the tractor. Be sure that people, livestock and pets are clear of machinery while operating.

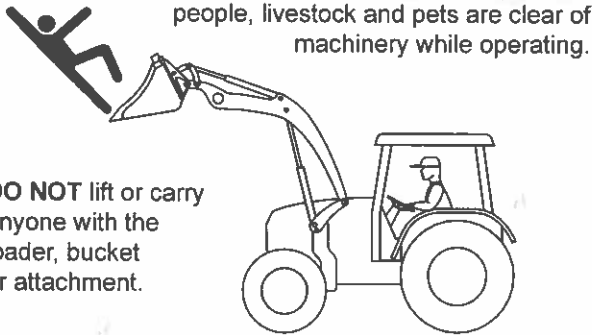

**DO NOT** lift or carry anyone with the loader, bucket or attachment.

### High Lift Loaders

High lift loader require tractors with a long wheel base. The rear wheels need to be set out all the way or preferably dual rear wheels and adequate ballast. (See ballast calculations in your loader's operator manual.)

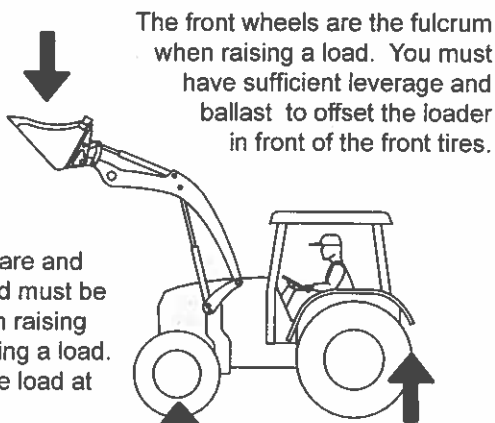

The front wheels are the fulcrum when raising a load. You must have sufficient leverage and ballast to offset the loader in front of the front tires.

Extreme care and slow speed must be used when raising and dumping a load. Monitor the load at all times.

**FULCRUM**

### Avoid Rollover

Your tractor may rollover, resulting in death or serious injury. **To avoid rollover:**

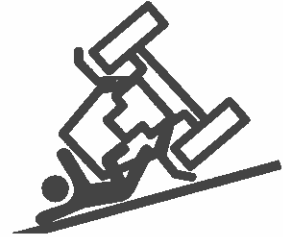

- Travel at a slow speed;
- Carry loads close to the ground;
- Avoid sharp turns and sudden movements on slopes;
- Avoid holes, ditches and other obstructions which may cause the tractor to rollover;
- Balance load so weight is evenly distributed and load is stable;
- Be extra careful when operating on slopes and do not operate on excessively steep slopes;
- Do not exceed the load capacity of your equipment;
- Be certain tractor tire spacing and rear ballast are correct before using equipment;
- Approach large round or square bales on a slope with the tractor facing uphill.

### Avoid Power Lines & Underground Utilities

Death or serious injury can result if equipment comes near or contacts power lines.

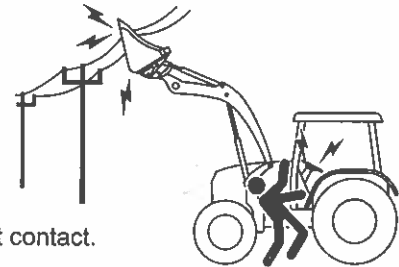

Electrocution can occur without direct contact.

Check clearance before raising equipment.

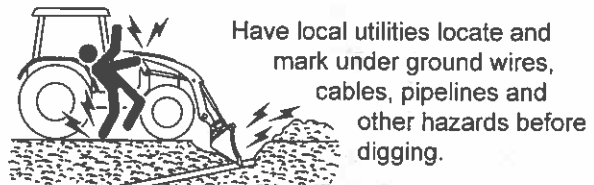

Have local utilities locate and mark under ground wires, cables, pipelines and other hazards before digging.

**DO NOT** leave the operator's seat if any part of the equipment contacts electric lines or cables.

### Lower Operating Speed

Lower your operating speed while digging, loading or performing heavy operations.

Move at slow speeds on rough or uneven terrain while keeping the load low.

### Replace Safety Signs

Replace missing or damaged safety signs.

Safety signs & part no. locations are identified in this manual.

Replacement safety signs are available from your Westendorf dealer at no cost.

## SECTION 2: SAFETY

### Prevent Falling Loads

**ALWAYS** secure the load at the source.

Round bales, square bales, posts, stones, logs, and other objects can fall or roll from a raised loader or attachment, which may crush the operator or bystanders.

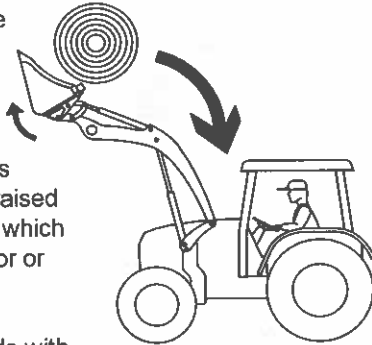

Handle all raised loads with caution. Keep eyes on load while raising or lowering.

- **DO NOT** carry items that may shift in the loader bucket or attachment.
- **DO NOT** handle round or square bales unless the loader is equipped with the proper bale handling attachment.
- **DO NOT** handle bales with the pallet fork attachment.
- **NEVER** travel with a raised load.
- **ALWAYS** carry loads low and close to the ground.

### Transport Loads Safely

Use the proper attachment to lift and carry the load.

Follow the instructions in the appropriate operator's manual for any loader attachments.

Carry loads low and slightly rolled back.

Travel **SLOW** and avoid slopes.

### Raised Loader

A raised loader can fall unexpectedly, resulting in death or serious injury.

**NEVER** enter the area under a raised loader or attachments.

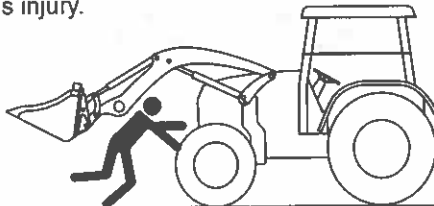

Lower bucket or attachments to the ground, place tractor transmission in park, shut off engine and remove key before servicing loader or attachments.

Detach loader from tractor to service the tractor.

### Avoid High Pressure Fluids

Escaping fluid under pressure can penetrate the skin causing serious injury.



Avoid the hazard by relieving pressure before connecting or disconnecting hydraulic lines. Tighten all connections before applying pressure.

Search for leaks with a piece of cardboard or wood. Protect hands and body from high pressure fluids.

If an accident occurs, see a doctor immediately. Any fluid injected into the skin must be surgically removed within a few hours or serious infection may result. Doctors unfamiliar with this type of injury should reference a knowledgeable medical source.

**DO NOT** mount a valve with direct mount joystick inside the tractor cab. Use only a remote cable inside cab.

### Hydraulic Control Functions

Check the loader response to the control lever movement. The loader should respond according to the ASAE standards shown. If response is incorrect, check the hydraulic hose connections at the tractor and manifold and correct if necessary. 1-Lever control functions will be shown throughout the manual, refer back to this section for operation regarding the 2-Lever control.

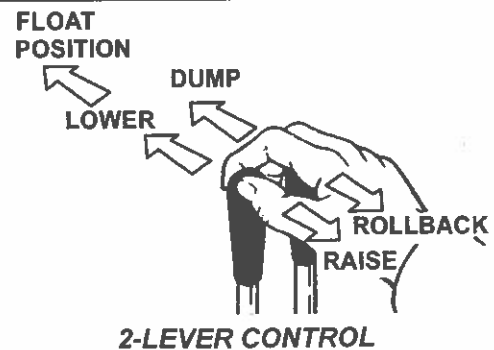
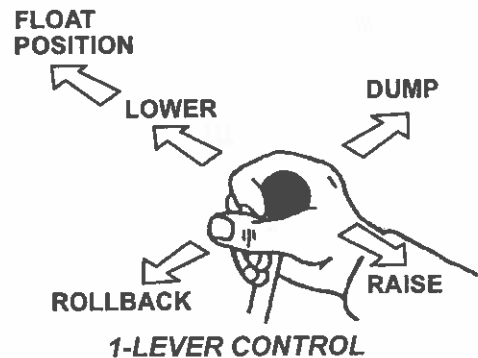

ASAE standard S335.4 shown in above illustrations

## SECTION 2: SAFETY

This engineering practice is intended as a guide to determine the minimum ballast and tread settings recommended for the operation of a front loader mounted on a 2WD tractor or a tractor with front assist. These ballast and tread setting recommendations are intended to reduce the risk of vehicle over-turn during typical operation.

**BALLAST** refers to cast weights or fluid added to rear tractor tires. Hitch ballast refers to a weight or an implement attached to the tractor three-point hitch.

**GROSS VEHICLE WEIGHT (GVW)** is the sum of front and rear axle weight caused by the mass of the tractor, loader, attachment, payload, ballast and hitch ballast.

### Determination of Ballast

#### **WARNING** CRUSHING HAZARD.

To prevent personal injury or death from tractor loader roll-over, add the recommended amount of ballast to the tractor. Always use a ROPS and wear a seatbelt.

The operational ballast criterion has been met when a minimum of 25% of the gross vehicle weight is retained on the rear axle in a static condition on level ground.

• A mass equivalent to the Lift Capacity maximum height should be placed in the loader bucket, with the boom raised until the bucket pivot pin is the same distance from the ground as the boom pivot (farthest forward position). The rear axle weight and gross vehicle weight should be measured on hard level ground ( $\pm 1^\circ$ ) under these conditions. See Figure 1.

• Ballast must be added to the rear wheels and/or hitch

#### **NOTICE** TRACTOR DAMAGE.

To avoid tractor damage use hitch ballast. Failure to use ballast can cause the front axle or other tractor components to be overloaded during loader operation.

until the rear axle weight on level ground is a minimum of 25% of the gross vehicle weight. Ballast added to the rear hitch should be kept as low as practical.

• When a loader is used in a dedicated situation, an operator may determine the appropriate ballast, based on the maximum load to be carried.  
• We recommend ballast, based on the criteria listed in above and knowledge of the physical characteristics of the tractor.

### Types of Ballast

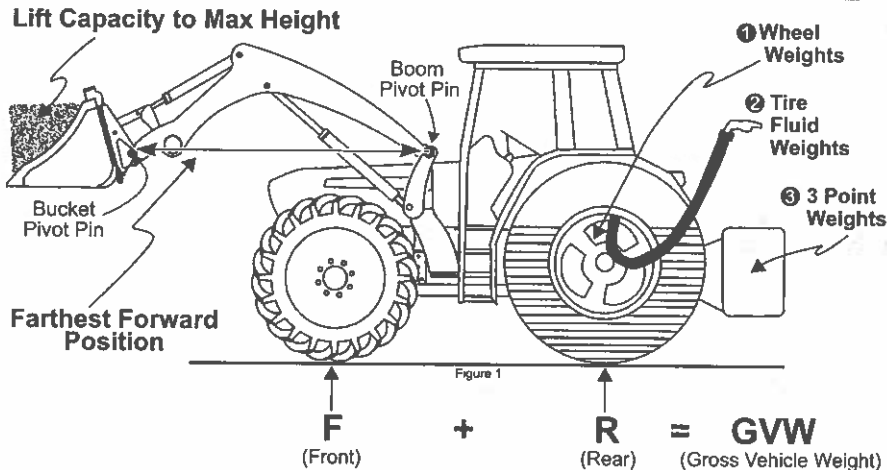

### Three Simple Steps

**STEP 1:** Put weight in the bucket equivalent to the lift capacity of the loader at full lift height. The lift capacity can be found in several locations:

- Operators manual
- Company Literature
- Visit us online at [www.loaders.com](http://www.loaders.com)
- Or Call Us at 712-423-2762

**STEP 2:** At the scale get the gross vehicle weight (GVW) with the loader raised so the bucket pivot pin is as high as the boom pivot pin. See Figure 1. Then weigh the rear axle (R).

**STEP 3:** Formulas to figure ballast.  
 $GVW \times 25\% = \text{Required Rear Axle Weight (RRAW)}$

< IS LESS THAN > IS GREATER THAN

If  $R > RRAW = \text{No Ballast Required}$

If  $R < RRAW = \text{Ballast Required}$

Figure Rear Ballast Required (RBR):

$RRAW - R = RBR$

$RBR \times 133\% = \text{Ballast Required}$

*Note: Since adding ballast increases the total weight adding the difference will not be enough. You need to add approximately 133% of the difference. Depending on where you add the ballast in respect to the rear axle the amount of weight may vary.*

### Glossary of Terms

GVW = Gross Vehical Weight  
F = Front Axle Weight  
R = Rear Axle Weight  
RRAW = Required Rear Axle Weight  
RBR = Rear Ballast Required  
< is Less than and > is Greater than

### Minimum Tread Settings

The rear wheel width is the most important specification to the balance of your tractor loader operation. Always use approved ROPS and fasten your seat belt.

Minimum tread settings are recommended to provide static stability on a side slope up to 15 degrees under proper rear ballast conditions listed in above. If minimum tread settings are not available in your mounting instructions, minimum rear tread settings should be selected from the following chart:

TRACTOR MASS		MINIMUM REAR TREAD SETTING		
Kg	Lbs	mm	in.	Ⓐ
<2250	<4950	1575	62.0	
2250-3650	4950-8030	1675	65.9	
>3650	>8030	1825	71.8	

**Note:** These tread settings are recommended for a standard tractor configuration. A tractor with a high center of gravity or an unusual configuration may require a wider minimum tread setting to achieve the same level of stability.

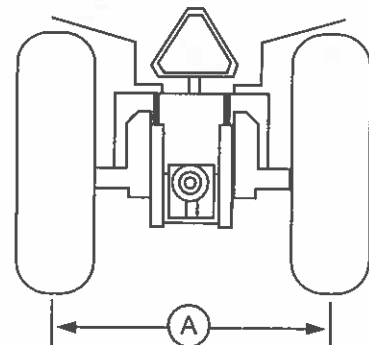

This information refers to ASAE S301.3, Front-End Agricultural Loader Ratings and ASAE S390.3, Definitions and Classifications of Agricultural Field Equipment, to EN12525:2000 Agricultural machinery - Front Loaders - Safety.

**SECTION 2: SAFETY**

**Round Bale Safety**

Handle all raised loads with caution. Keep eyes on load while lowering or raising to help prevent personal injury or death caused by falling or crushing loads:

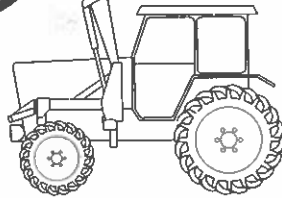
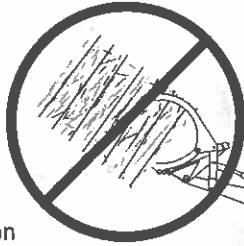

- **DO NOT** handle round or square bales unless the loader is equipped with an approved bale handling attachment.
- Brush Crusher is **NOT** designed for handling hay.
- **NEVER** travel with a raised load.
- **ALWAYS** carry loads low and drive slow.

Lockout valve detents to prevent automatic loader movement (See tractor's owners manual).

**Balance Uneven Loads Properly**

Due to the nature of trees and limbs being heavier on one end than the other, use extra caution when handling uneven loads.

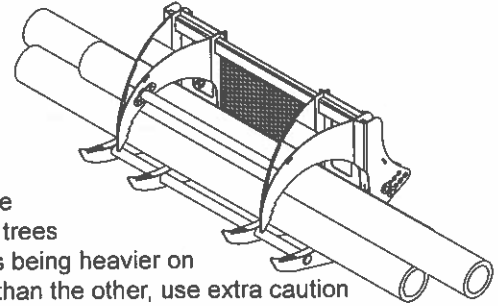

- **DO** center the weight of the uneven load in your attachment.
- **AVOID** twisting loads.
- **ALWAYS** carry loads low and drive slow.
- **ALWAYS** be alert of your surrounding when carrying loads.

**Handling Your Brush Crusher™**

To help prevent personal injury, do not attempt to pick up the attachment by yourself. Use a mechanical device or team lift when handling the attachment. Use extreme caution when moving and handling this attachment. When not properly secured the teeth assemblies will swing together and could cause personal injury.

**Using Your Brush Crusher™ & Safety Decal Locations**

We have given you the Cautions, Warnings, and Dangers that we could foresee, however due to the flexibility of the product there are uses not thought of yet. Please use common sense and good judgment when operating these units. *If it does not appear to be safe, it isn't.*

Prior to actual work, operate the unit to get an idea of how it works. New operators should read the operator's manual.



**SAFETY DECAL LOCATION**

These decals are located on the loader and attachments. If any decals become damaged or illegible you can order replacements, free of charge, by writing to:

Westendorf Mfg. Co., Inc.  
PO Box 29  
Onawa, IA 51040-0029

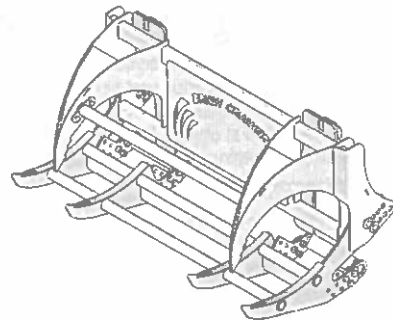





## SECTION 4: OPERATION

### The Mechanical Advantage

The Westendorf Brush Crusher is a unique product, take time to understand how it operates. The mechanical advantage allows you to use the bucket cylinders to operate the teeth, saving you the expense of added hydraulics. The Brush Crusher is a very powerful tool, please review the following tips when operating this unit.

### Approaching the Load

Approaching the load will vary based on the loader and Brush Crusher model you have. Pay particular attention to the teeth when they are in the open position. Whichever set of teeth are closer to the ground determines how to approach the load. Position the claw around the object by lowering your loader arms and driving into or toward from the object (Figure 1). Draw the object into the claws by closing the teeth and lowering the arms.

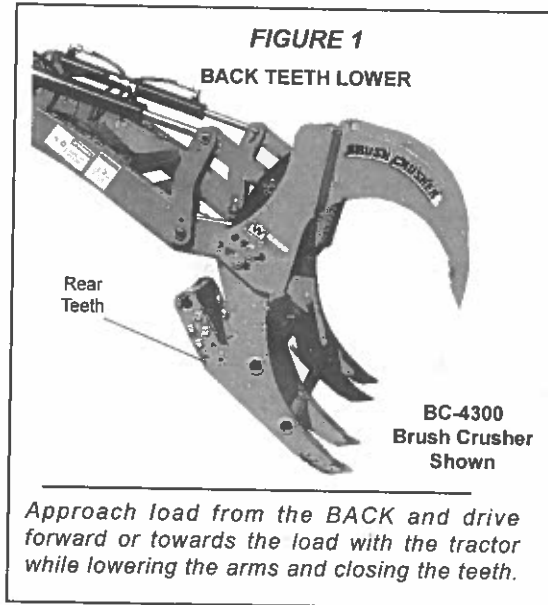

### **NOTICE** CRUSHING HAZARD.

To prevent tractor or equipment damage:

- Know the limitations of your equipment.
- DO NOT exceed the capacity that your loader or Brush Crusher™ can handle safely.
- Center the weight of the load in the attachment.
- Avoid twisting loads.
- See your tractor operator's manual for ballast and tire setting recommendations.



*At times you may want to put the loader into FLOAT when closing the teeth. This allows the Brush Crusher to adjust or capture the load.*

## SECTION 5: SERVICE & MAINTENANCE

### Maintenance Checklist

Perform scheduled maintenance as outlined below.

1. Lower the bucket or attachment to the ground, or remove on level surface to perform maintenance.
2. Turn off tractor engine, remove key, and set tractor parking brake before performing inspections.

### **WARNING** CRUSHING HAZARD.

To prevent automatic movement:

- Operate loader from the operator's seat only.
- Remain at the controls until the operation cycle is fully complete.
- Lock-out valve "detent" when operating loader. See your tractor operator's manual.

3. Relieve hydraulic pressure. Use wood or cardboard to inspect hydraulic hoses, lines and fittings for damage, wear and leaks. Repair or replace as necessary.

4. Inspect pivot pins for wear. Be certain retaining roll pins are installed on each pin.

5. Check all mounting hardware for tightness. Use the torque charts in this section.

6. Lubricate BC-4300 grease fittings as shown below.

7. While in use, listen for abnormal or unusual sounds that may indicate worn, loose or damaged parts.

8. After each use, clean loader and attachment and verify all safety decals are legible and not damaged. Replace damaged safety decals.

### Lubrication

Grease all zerks noted below every 10-12 hours. Failure to grease the Brush Crusher may result in premature wear. All zerks can be accessed with the loader on tractor, arms down and the attachment level.

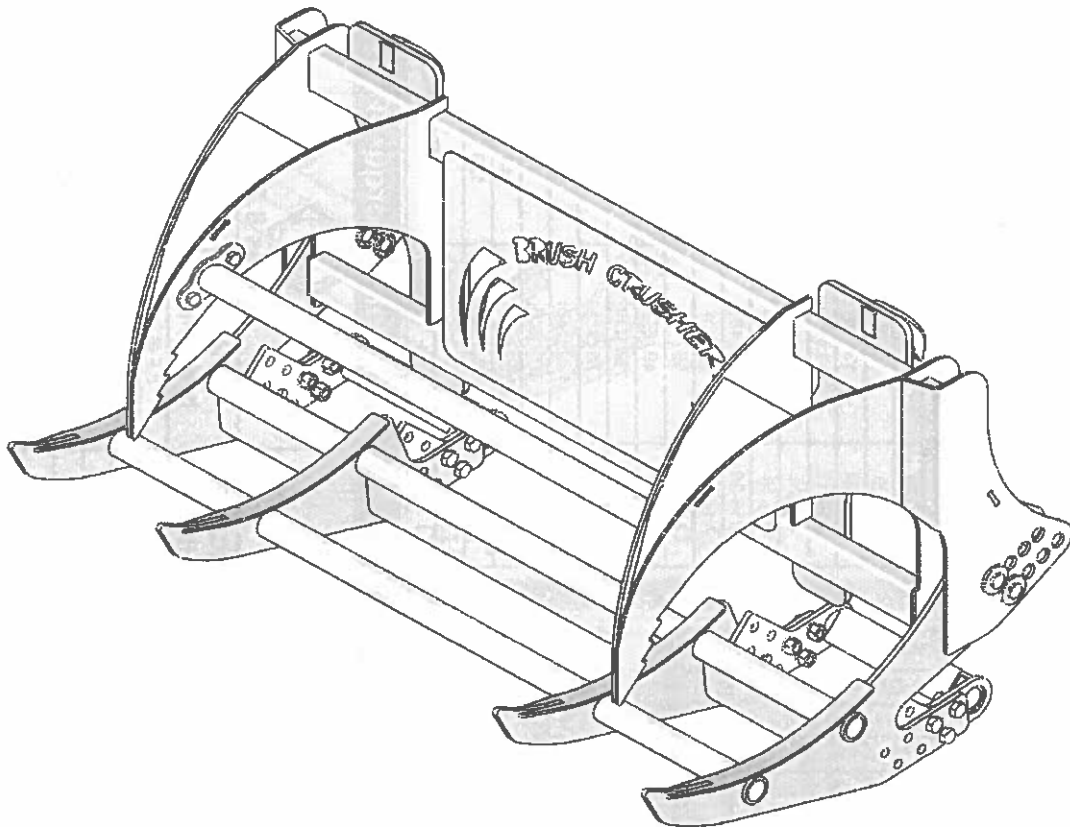

**SECTION 5: SERVICE & MAINTENANCE**

### SAE Torque-Tension Values

Bolt Size	Grade 2		Grade 5		Grade 8	
	DRY	LUBRICATED	DRY	LUBRICATED	DRY	LUBRICATED
	lb-ft (N•m)	lb-ft (N•m)	lb-ft (N•m)	lb-ft (N•m)	lb-ft (N•m)	lb-ft (N•m)
1/4-28	6 (9)	5 (6)	10 (14)	7 (10)	14 (19)	10 (14)
1/4-20	6 (9)	4 (5)	8 (11)	6 (9)	12 (16)	9 (13)
5/16-24	13 (18)	9 (13)	19 (26)	14 (19)	27 (36)	20 (27)
5/16-18	11 (15)	8 (11)	17 (23)	13 (18)	25 (33)	18 (25)
3/8-24	23 (31)	17 (23)	35 (47)	26 (35)	49 (67)	37 (50)
3/8-16	20 (27)	15 (20)	31 (42)	23 (31)	44 (59)	33 (44)
7/16-20	36 (48)	27 (36)	55 (75)	41 (56)	78 (106)	58 (79)
7/16-14	32 (43)	25 (33)	49 (67)	37 (50)	70 (95)	52 (71)
1/2-20	55 (75)	41 (56)	85 (115)	64 (86)	120 (163)	90 (122)
1/2-13	49 (67)	37 (50)	75 (100)	57 (77)	106 (144)	80 (108)
9/16-18	78 (106)	59 (80)	121 (164)	91 (123)	171 (232)	128 (174)
9/16-12	70 (95)	53 (72)	109 (148)	82 (111)	154 (209)	115 (156)
5/8-18	110 (149)	82 (111)	170 (231)	127 (172)	240 (325)	180 (244)
5/8-11	97 (132)	73 (99)	150 (204)	113 (153)	212 (287)	159 (216)
3/4-16	192 (260)	144 (195)	297 (403)	223 (302)	420 (569)	315 (427)
3/4-10	172 (233)	129 (175)	269 (365)	201 (273)	376 (510)	282 (382)
1-12			704 (954)	528 (716)	995 (1350)	746 (1010)
1-8			644 (873)	483 (655)	909 (1230)	681 (923)

- Torque Chart**
1. ALWAYS tighten hardware to these values unless a different torque value or tightening procedure is listed for a specific application.
  2. Fasteners MUST always be replaced with the same grade as specified in the manual parts list.
  3. Always use proper tools for tightening hardware: SAE for SAE hardware and Metric for Metric hardware.
  4. Make sure fastener threads are clean and you start thread engagement properly.
  5. All torque values are given to specifications used on hardware defined by SAE J1701 & J1701M.
- "Lubricated" means coated with a lubricant such as engine oil, fasteners with phosphate and oil coatings.
- "Dry" means plain or zinc plated without any lubrication.

### Metric Torque-Tension Values

Bolt Size	Class 4.8		Class 8.8		Class 10.9		Class 12.9	
	DRY	LUBRICATED	DRY	LUBRICATED	DRY	LUBRICATED	DRY	LUBRICATED
	lb-ft (N•m)	lb-ft (N•m)	lb-ft (N•m)	lb-ft (N•m)	lb-ft (N•m)	lb-ft (N•m)	lb-ft (N•m)	lb-ft (N•m)
M6	4.7 (3.5)	6 (4.5)	8.9 (6.5)	11.3 (8.5)	13 (9.5)	16.5 (12)	15.5 (11.5)	19.5 (14.5)
M8	11.5 (8.5)	14.5 (10.5)	22 (16)	27.5 (20)	32 (23.5)	40 (29.5)	37 (27.5)	47 (35)
M10	23 (17)	29 (21)	43 (32)	55 (40)	63 (46)	80 (59)	75 (55)	95 (70)
M12	40 (29.5)	50 (37)	75 (55)	95 (70)	110 (80)	140 (105)	130 (95)	165 (120)
M14	63 (46)	80 (59)	120 (88)	150 (110)	175 (130)	220 (165)	205 (150)	260 (190)
M16	100 (74)	125 (92)	190 (140)	240 (175)	275 (200)	350 (255)	320 (235)	400 (300)
M18	135 (100)	170 (125)	265 (195)	330 (245)	375 (275)	475 (350)	440 (325)	560 (410)
M20	190 (140)	245 (180)	375 (275)	475 (350)	530 (390)	675 (500)	625 (460)	790 (580)
M22	265 (195)	330 (245)	510 (375)	650 (480)	725 (535)	920 (680)	850 (625)	1080 (800)
M24	330 (245)	425 (315)	650 (480)	820 (600)	920 (680)	1150 (850)	1080 (800)	1350 (1000)

**SECTION 5: SERVICE & MAINTENANCE**

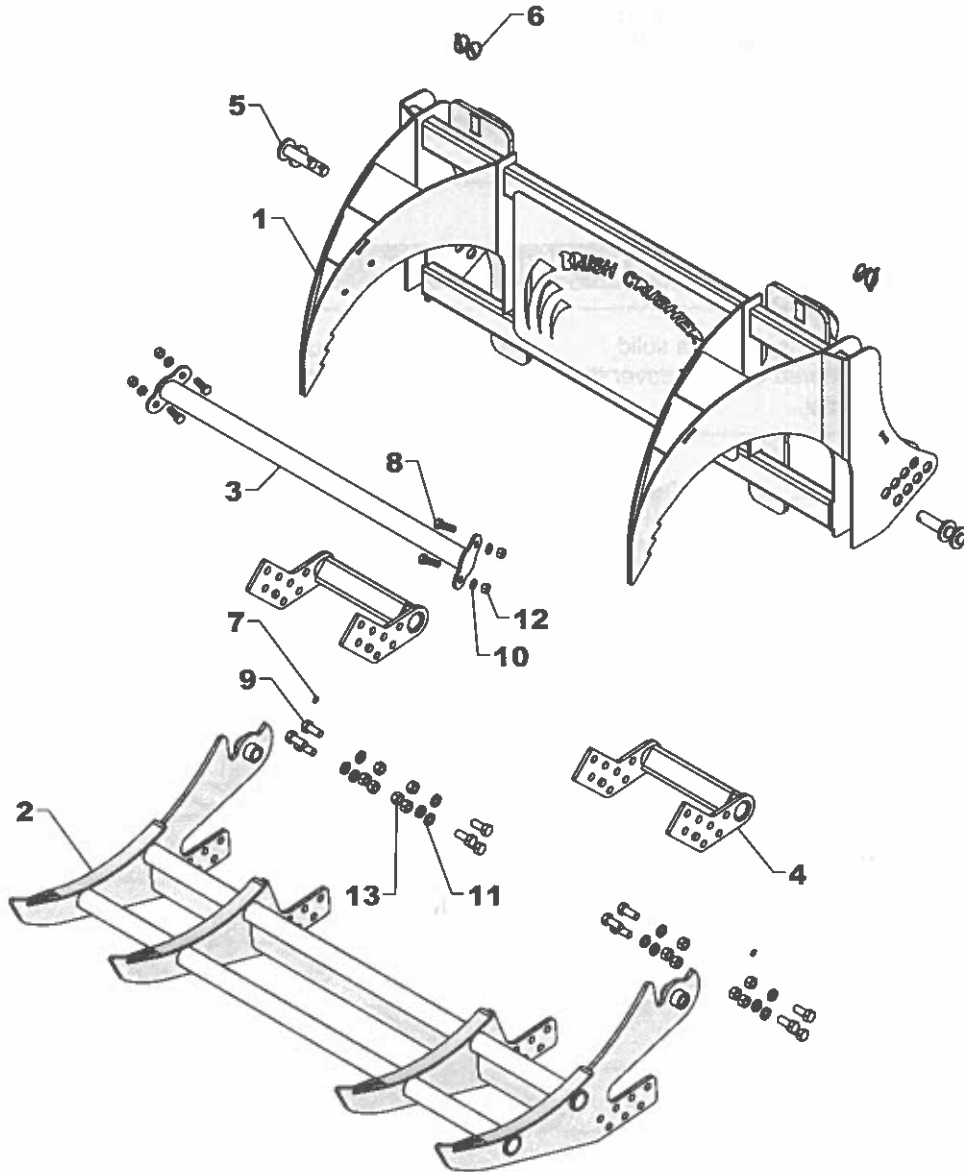

**BC-4400 REPLACEMENT PARTS**

REF #	PART #	DESCRIPTION	QTY
1	BCP-400AS	UPPER TOOTH ASSEMBLY	1
2	BCP-511AS	LOWER TOOTH ASSEMBLY	1
3	BCP-512AS	UPPER TOOTH TIE BAR	1
4	BCP-458AS	ARM STOP	2
5	BCP-486AS	PIN	4
6	QLP0400028	LYNCH PIN	4
7	ZER1805	GREASE FITTING	2

REF #	PART #	DESCRIPTION	QTY
8	HHS0813024	1/2" X 1 1/2" BOLT	4
9	HHS1011024	5/8" X 1 1/2" BOLT	12
10	LWM08	1/2" LOCK WASHER	4
11	LWM10	5/8" LOCK WASHER	12
12	HFN0813	1/2" NUT	4
13	HFN1011	5/8" NUT	12

WESTENDORF MFG CO., INC. • PH: (712) 423-2762 • FAX: (712) 423-1460 • sales@westendorfmfg.com • www.loaders.com

## SECTION 5: SERVICE & MAINTENANCE

### Preparing the Brush Crusher™ for Storage

- Replace damaged or missing parts including pins, hardware and decals.
- Clean the Brush Crusher thoroughly. Dirt attracts moisture which causes rust.
- Lubricate all grease fittings.
- Paint the loader or attachment when needed.

### Storing the Brush Crusher™

- Store attachments inside, if possible, on a solid, level surface, as shown. If stored outside, cover the unit with a waterproof material.
- Store Brush Crusher units out of way so they do not have to be moved between uses.

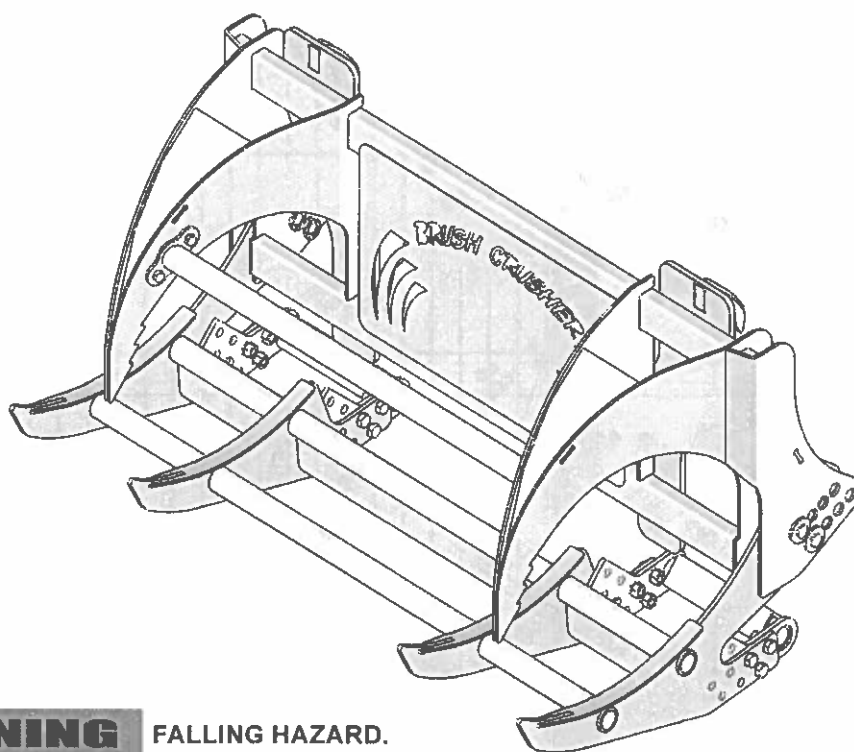

#### **⚠ WARNING** FALLING HAZARD.

To prevent serious injury or death:

- Store attachment inside, if possible, on hard level surface to avoid falling over.
- Protect against injuries from sharp points or edges on attachment.
- Keep children and bystanders away from storage area.





# WESTENDORF



## Exclusive Patented Features:

- Power-Mount™ - Mount & dismount loader hydraulically in One Step without tools or dangerous stands.
- Snap-Attach™ - The original quick change system that automatically locks attachments in place.
- Hydra-Snap™ - a single lever manifold that couples all the hoses in one smooth motion.
- Uni-Fit™ Brackets- Custom adjust the loader to fit your tractor for low-profile fit and smooth operation.

## Your One Stop Shop For Material Handling Solutions

- Loaders
- Buckets
- Bucket Accessories
- Tine Bucket
- Fork Bucket
- Quick-Mount Grab Forks
- Cat Claw 3D Grab Forks
- Bale Spears
- Stack Saver® I & II
- Bale Grab
- Squeezer
- Bale Handler
- Brush Crushers™
- V-Plow
- Dozer Blades
- Forklifts
- 3-Point Attachments
- Auto-Dump™
- Dual Tire Changer
- Landscaper™
- Hitch-N-Go™
- Lowboy Trailer
- Anhydrous Wagon™
- Running Gears
- Wagon Packages
- Cool Cap™ Canopy
- Dump Spreader
- More online at....

[www.loaders.com](http://www.loaders.com)